

COMMAND PRO

*GASEOUS FUEL 14, 20 AND 25HP  
OHV VERTICAL/HORIZONTAL*

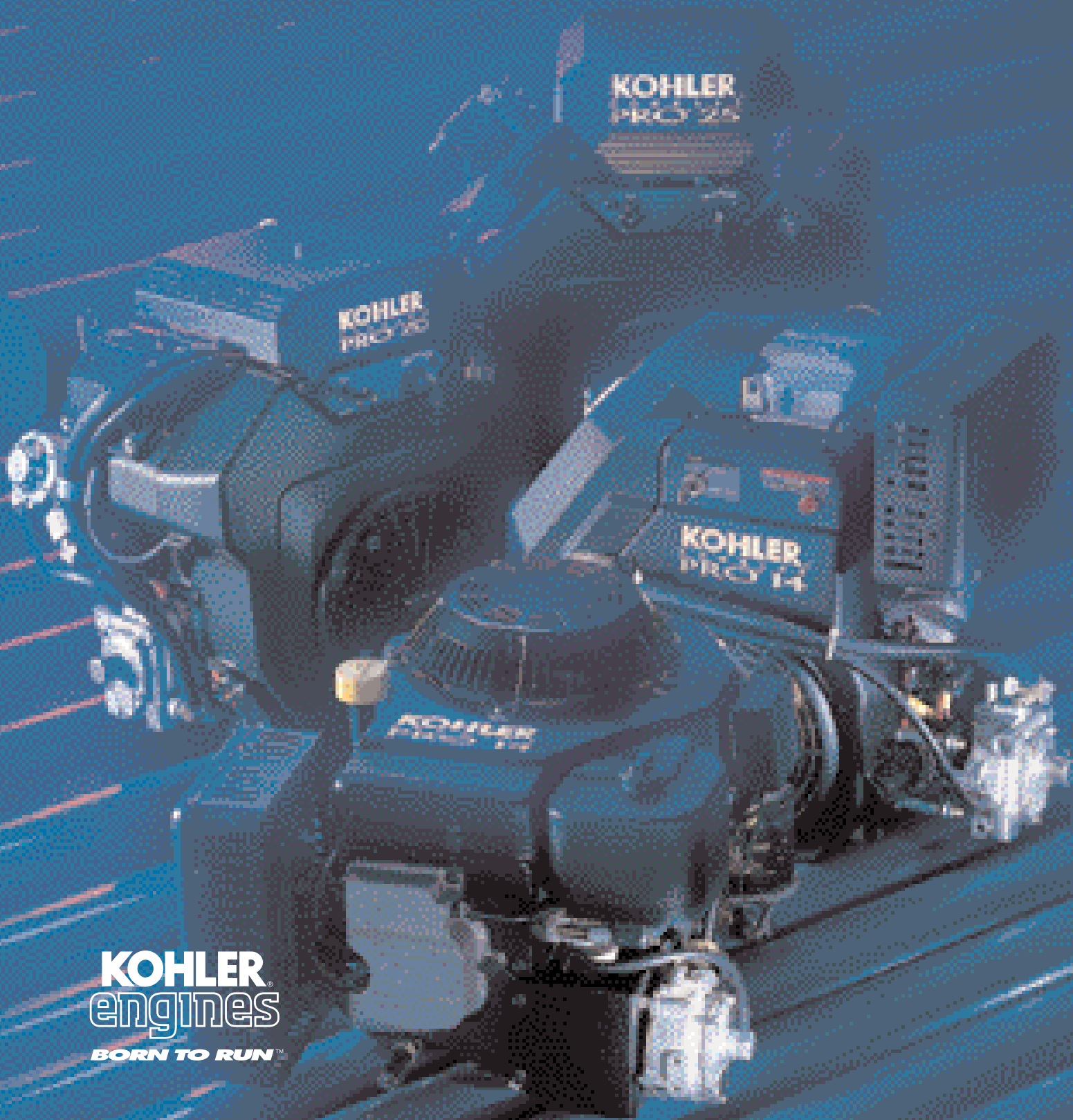

**KOHLER**  
**engines**  
**BORN TO RUN™**

# COMMAND PRO

14, 20 AND 25 HP OHV VERTICAL/HORIZONTAL SHAFT

## COMMAND PRO™ GASEOUS FUEL ENGINES

- Ideal for industrial, construction, rental, commercial and other outdoor power equipment
- LPG, LPG/NG, LPG/Gasoline choices
- Open loop and closed loop systems
- Vapor and liquid withdrawal
- Ready to use, right out of the box
- Factory-installed, two-stage regulator
- Factory-installed, lock-off solenoid
- CARB/EPA certified
- Two-year commercial warranty
- Kohler application assistance available



CH25 LPG/Gasoline, closed loop

### STANDARD FEATURES

Whether you choose gaseous fuel or gasoline, these important features are standard on all Command PRO engines:

#### OVERHEAD VALVE EFFICIENCY

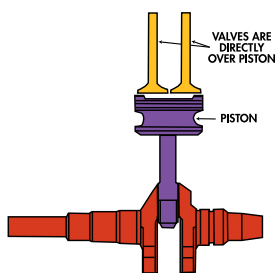

Overhead valve design increases power, boosts fuel economy, reduces oil consumption and virtually eliminates carbon build-up to keep your Command PRO engine running cleaner, stronger and longer.

#### HYDRAULIC VALVE SMOOTHNESS

Oil-pressurized valve lifters keep push rods in constant contact with rocker arms, eliminating valve adjustments. So you avoid expensive downtime and increase equipment productivity.

#### QUIET PERFORMANCE

Equipment operators and the environment benefit with Kohler quiet-plus features: hydraulic valve lifters, cam-ground pistons, helical gears and engineered-material blower housing.

#### RELIABLE ELECTRONIC IGNITION

With breakerless, inductive ignition, you get excellent all-weather starts even in temperatures as low as 10° F. Response is quick and stable.

Compared to a gasoline engine, LPG and natural gas (NG) offer many advantages:

- Less Carbon Monoxide (CO) emissions.
- Compliant with ozone non-attainment days in many cities.
- No evaporative fumes that are present during gasoline fills or spillage.
- Leaves no lead, carbon or sludge in the engine — that means less engine wear and lower maintenance costs.
- No gasoline vapor lock.
- Higher octane rating.
- Won't "spoil" over time — especially crucial for standby generator sets.
- Stable prices not affected by oil supplies or market conditions.
- Adapts easily to mobile applications (LPG only).

### OTHER CONSIDERATIONS

Before deciding on gaseous fuel, consider these other factors:

**Lower horsepower and torque.** Simply stated, gaseous fuel replaces a portion of the air normally drawn for combustion. That means less power compared to gasoline—about 10% less for LPG; about 20% less for natural gas or dual fuel.

**Cost.** Gaseous fuel components add cost to a spec. Prices can be 15% to 50% higher than a gasoline engine.

**Emissions.** Regardless of fuel type, equipment operators should avoid inhaling exhaust fumes. Engines should not be run in a closed building or a confined area.

# COMMAND PRO

14, 20 AND 25 HP OHV VERTICAL/HORIZONTAL SHAFT

## COMMAND PRO™ - GASEOUS FUEL OPTIONS

KOHLER Command PRO engines are available with the following gaseous fuel options:

### LPG Only

- Closed loop: CH14, CV14
- Open loop: CH20, CH25

### LPG/Natural Gas Dual Fuel

- Open loop: CH25

### LPG/Gasoline Dual Fuel

- Closed loop: CH25
- Open loop: CH25

(More models to follow)

## CLOSED VS. OPEN LOOP SYSTEMS

Gaseous fuel systems are either closed loop or open loop. These terms refer to whether the engine's air-to-fuel ratio is electronically monitored (closed loop) or not (open loop).

### Closed Loop (see diagram below)

This system relies upon two critical parts: an analog Electronic Control Unit (ECU) and an oxygen sensor. The system's fuel metering valve, installed in the fuel line, is activated by the ECU to provide either less or more fuel. The ECU engages when the oxygen sensor, installed in the exhaust, signals a change in oxygen levels. In this way, the ECU maintains a consistent air-to-fuel ratio at all loads and speeds.

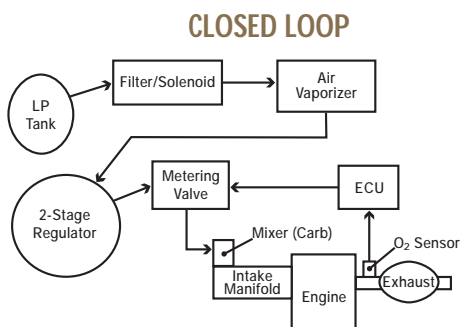

With a closed loop system, you can rely on a consistent air-to-fuel ratio regardless of fuel composition, air filter condition, ambient temperature, altitude or engine wear.

The advantages: enhanced engine performance and lower exhaust emissions. Emissions are reduced even further with a catalytic muffler, as featured on the CH14/CV14 LPG closed loop specs (not available on Twins).

### Open Loop

An open loop system has the same components as closed loop, except the ECU and oxygen sensor are not included.

## ENGINES ARE READY TO USE

Command PRO gaseous fuel engines are ready to use, right out of the box. All gaseous fuel components are engine-mounted and factory-tested before delivery. They provide reliable starts, dependable performance and maximum power when you need them, every time you need them.

Kohler's two-year commercial warranty applies to the entire engine, including the following gaseous fuel components:



### AIR VAPORIZER

Converts liquefied fuel to vapor before reaching the two-stage regulator. (Not needed on vapor withdrawal gaseous fuel specs.)



### TWO-STAGE REGULATOR

Reduces fuel tank pressure, regulates and maintains that pressure in its **primary** chamber, then reduces it again in a **secondary** chamber to nearly atmospheric pressure to prevent excess fuel from flowing.



### LOCK-OFF SOLENOID

Automatically shuts off fuel when engine stops as required by U.L. Also includes internal, replaceable fuel filter.

# COMMAND PRO

14, 20 AND 25 HP OHV VERTICAL/HORIZONTAL SHAFT

## CH14 AND CV14 ENGINES



**CLOSED LOOP - VERTICAL**  
CV14 LPG: PA-14106

Shown with optional recoil housing for foam filter.  
**Note:** Recoil start not available. 12V required for ECU.



**CLOSED LOOP - HORIZONTAL**  
CH14 LPG: Special Order

### STANDARD FEATURES

- |                                 |                                  |
|---------------------------------|----------------------------------|
| • Lock-off solenoid w/filter    | • Balance system                 |
| • Two-stage regulator           | • Full pressure lubrication      |
| • Electronic Control Unit (ECU) | • Spin-on oil filter             |
| • Oxygen sensor                 | • Oil Sentry™ system             |
| • Catalytic pillow muffler      | • 12V electric start, w/solenoid |
| • Overhead valve design         | • 15A charging system            |
| • Electronic ignition           | • Unitized choke/throttle (CV)   |
| • Hydraulic valve lifters       | • Separate choke/throttle (CH)   |
| • Steel intake valve            | • Plastic blower housing (CV)    |
| • Stellite exhaust valve        | • Metal blower housing (CH)      |
| • Dual element air cleaner      | • Hardened crankshaft            |

### POPULAR FACTORY OPTIONS

- |                                       |                      |
|---------------------------------------|----------------------|
| • Exhaust deflectors                  | • Remote oil filter  |
| • Spark arrestors                     | • Metal grass screen |
| • Crankshaft choices                  | • 5% governing (CH)  |
| • Separate choke/throttle (CV)        | • Flywheel PTOs (CH) |
| • Recoil housing and foam filter (CV) |                      |

Kohler Co. reserves the right to change product specifications, designs and standard equipment without notice and without incurring obligation.

## ENGINE PERFORMANCE

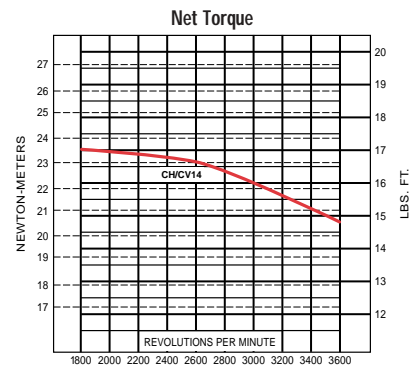
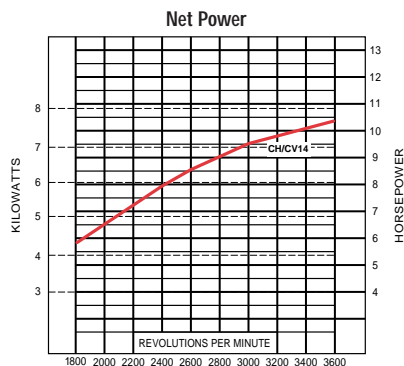
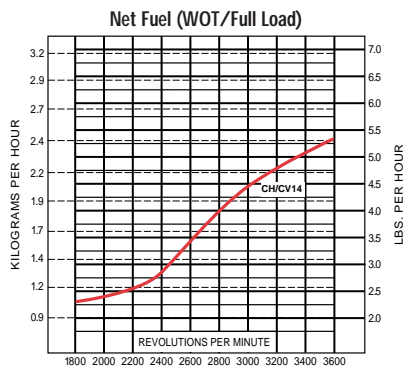

CH14 LPG, closed loop  
CV14 LPG, closed loop

# COMMAND PRO

14, 20 AND 25 HP OHV VERTICAL/HORIZONTAL SHAFT

## CH14 AND CV14

### CH14 LPG, CLOSED LOOP

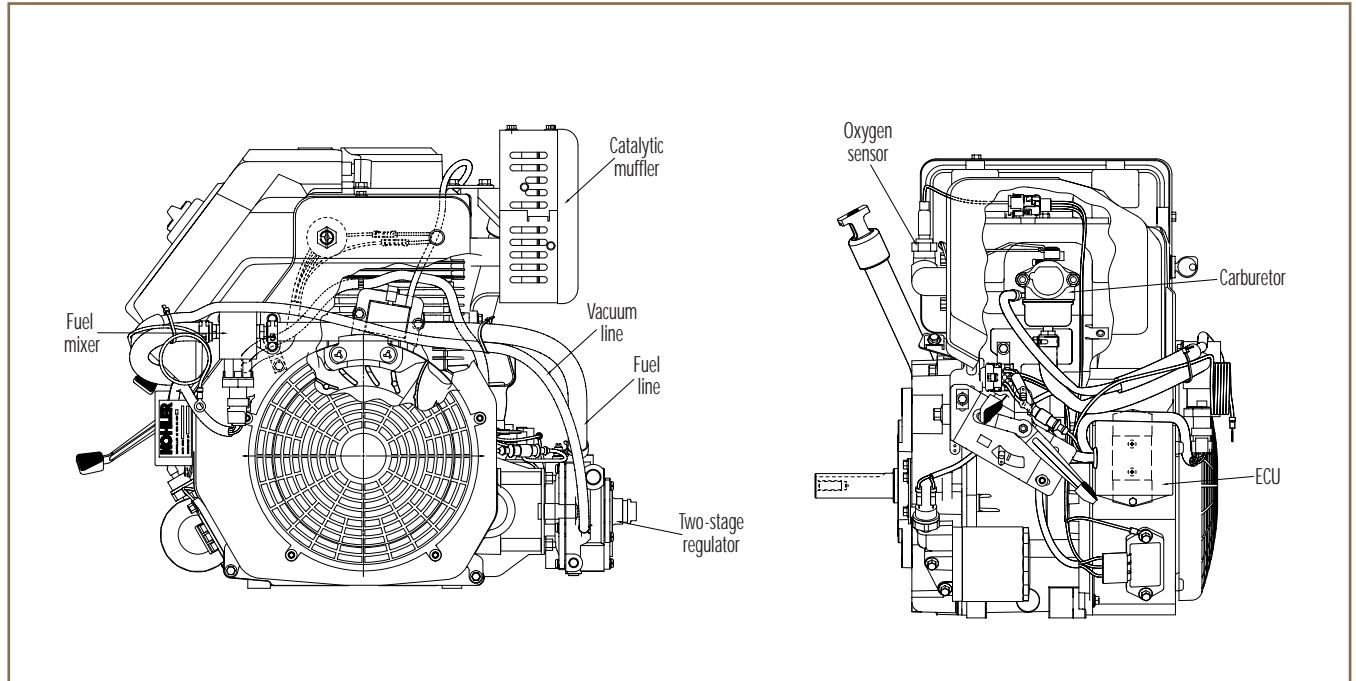

### CV14 LPG, CLOSED LOOP

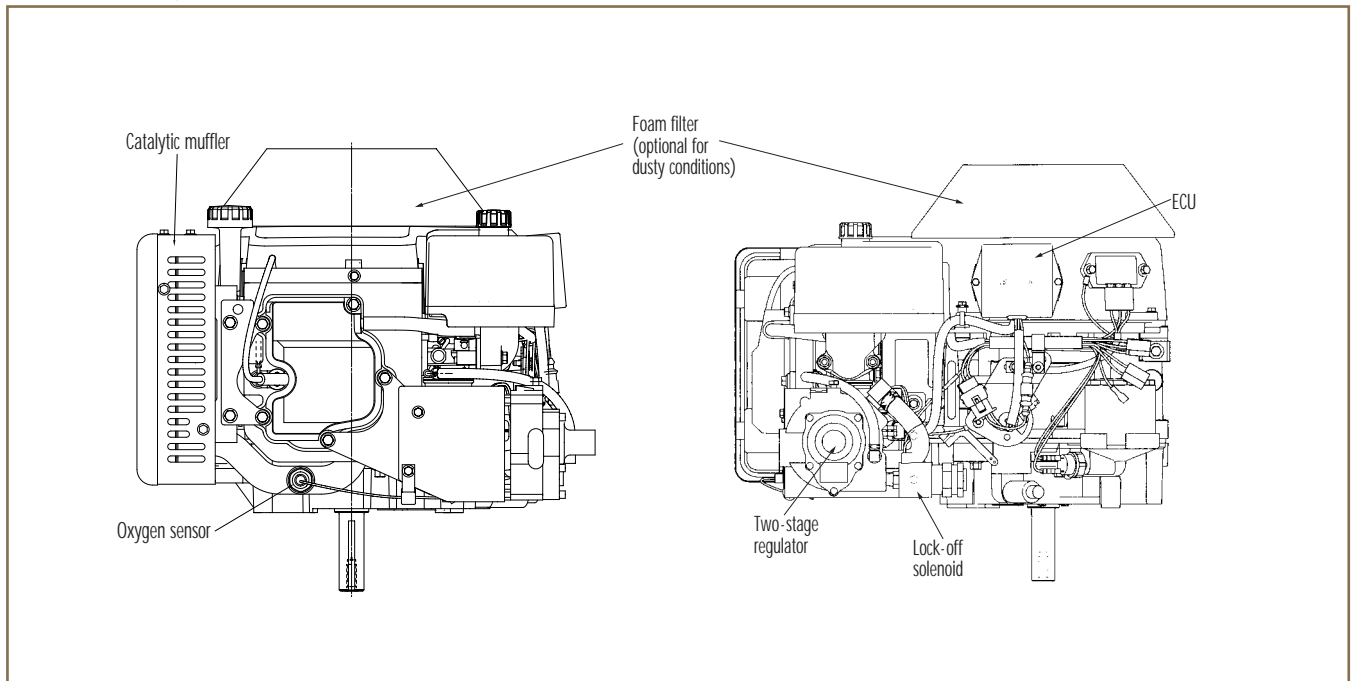

NOTE: All equipment applications using gaseous fuels must be reviewed by Kohler application engineering. This will help assure compliance with all environmental regulations, as well as provide assistance with other application-related issues. Contact your Kohler sales representative to begin the review process.



# COMMAND PRO

14, 20 AND 25 HP OHV VERTICAL/HORIZONTAL SHAFT

## CH20 AND CH25 ENGINES



CH20 LPG, open loop

### OPEN LOOP

- CH20 LPG: PA-64570
- CH25 LPG: PA-68640
- CH25 LPG/Gasoline: Special order
- CH25 LPG/NG: Special order



CH25 LPG/Gasoline, closed loop

### CLOSED LOOP

- CH25 LPG/Gasoline: Special Order

### STANDARD FEATURES

- Lock-off solenoid w/filter
- Air vaporizer (except LPG/NG)
- Two-stage regulator
- ECU (closed loop only)
- Oxygen sensor (closed loop only)
- Canister muffler
- Overhead valve design
- Electronic ignition
- 12V electric start, solenoid shift
- 20A charging system
- Stellite exhaust valves
- Hydraulic valve lifters
- Cast oil cooler (CH25)
- Oil Sentry™ system
- Spin-on oil filter
- Dual oil drains
- Full pressure lubrication
- Dual element air cleaner
- Large air filter (CH25)
- Variable speed governor

### POPULAR FACTORY OPTIONS

- Side muffler (open loop only)
- Muffler guards
- Exhaust deflector
- Spark arrestors
- Metal grass screen/guard
- Engine-mounted controls
- Remote oil filter
- 5% governing system
- 15A or 25A charging system
- Crankshaft choices
- Flywheel PTOs
- PTO thrust bearing (CH25)

Kohler Co. reserves the right to change product specifications, designs and standard equipment without notice and without incurring obligation.

### ENGINE PERFORMANCE

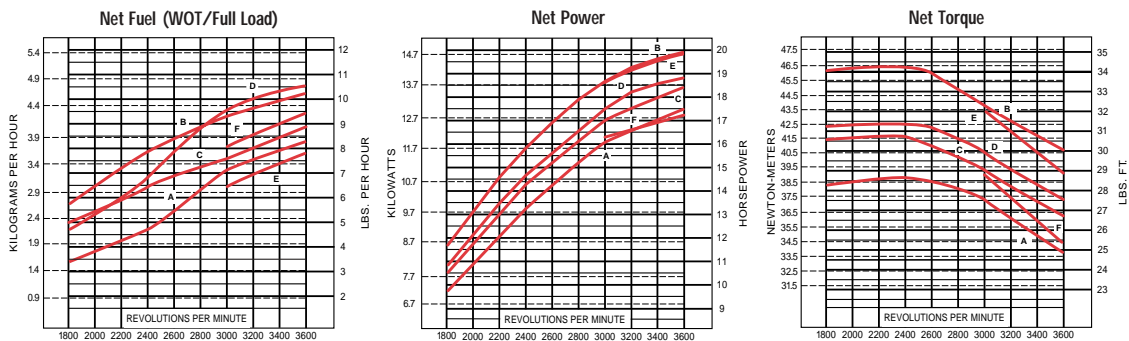

A - CH20 LPG, open loop B - CH25 LPG, open loop C - CH25 LPG, closed loop (when a dual fuel with Gasoline) D - CH25 LPG, open loop (when a dual fuel with Gasoline)  
E - CH25 LPG, open loop (when a dual fuel with NG) (Generator spec @ 3000/3600 rpm) F - CH25 NG, open loop (when a dual fuel with LPG) (Generator spec @ 3000/3600 rpm)

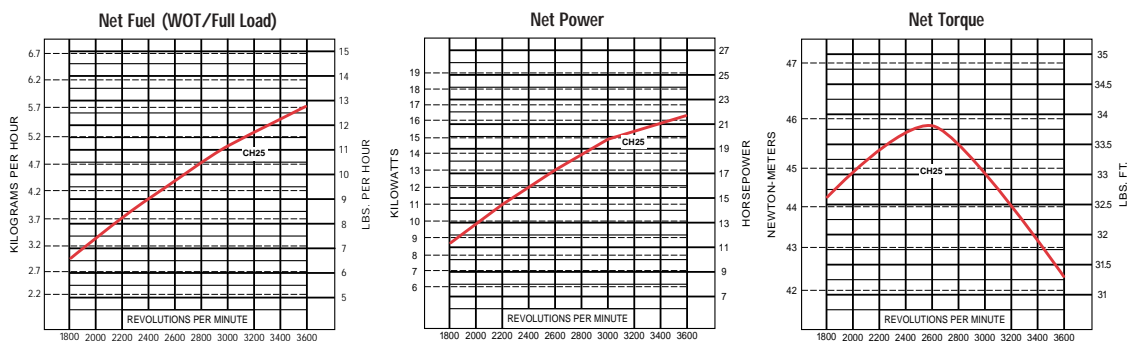

• CH25 Gasoline, closed loop (when a dual fuel with LPG) • CH25 Gasoline, open loop (when a dual fuel with LPG)

# COMMAND PRO

14, 20 AND 25 HP OHV VERTICAL/HORIZONTAL SHAFT V-TWIN

## CH20 AND CH25

### CH20 LPG, OPEN LOOP

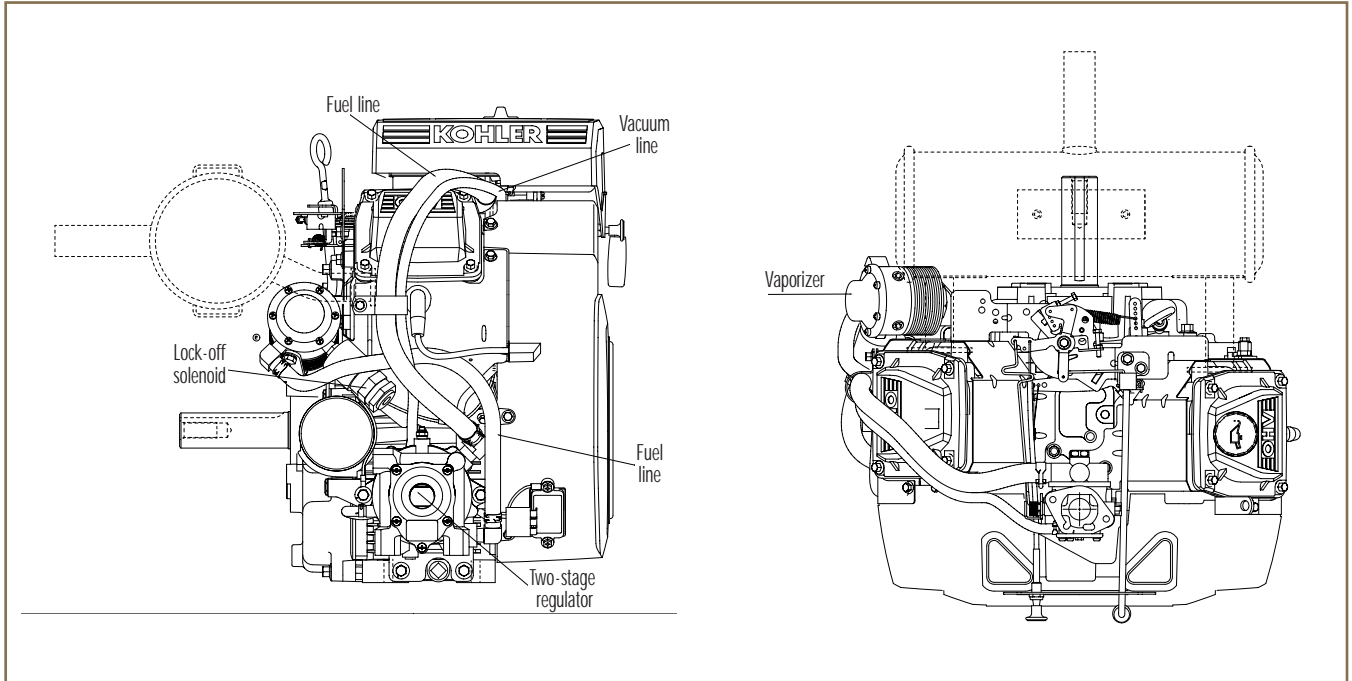

### CH25 LPG/GASOLINE, CLOSED LOOP

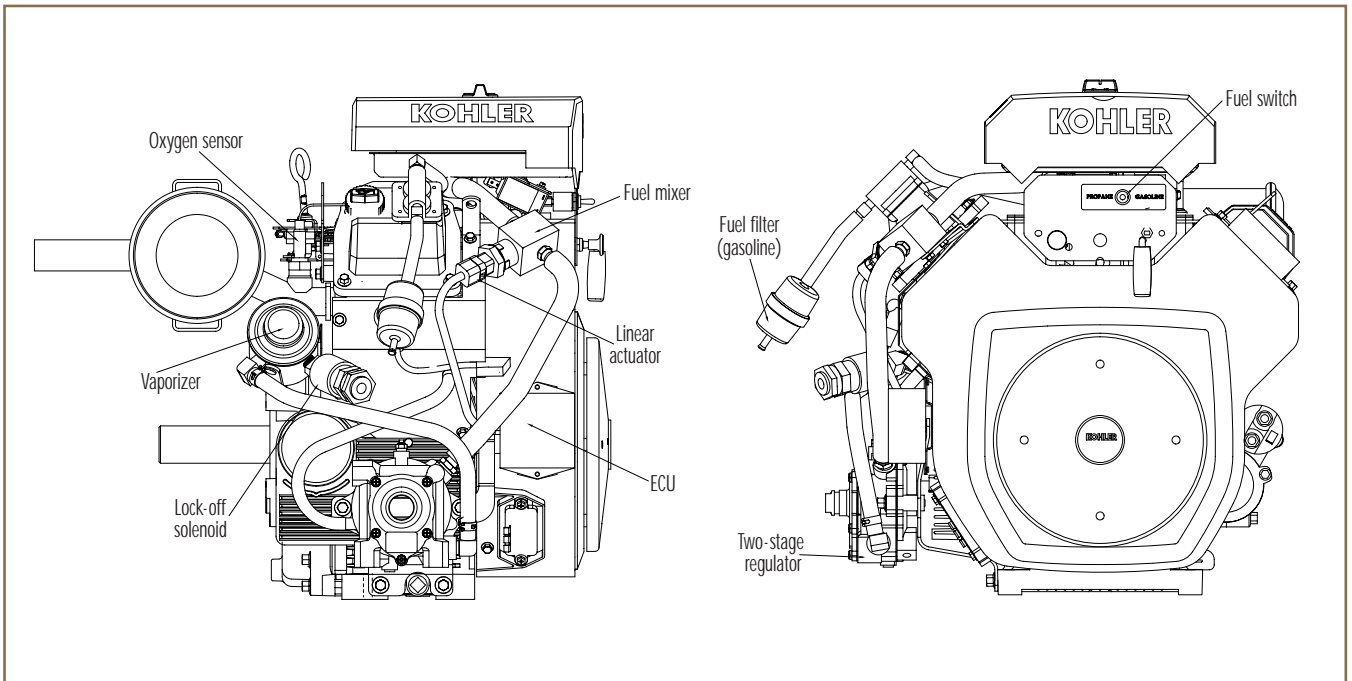

**NOTE:** All equipment applications using gaseous fuels must be reviewed by Kohler application engineering. This will help assure compliance with all environmental regulations, as well as provide assistance with other application-related issues. Contact your Kohler sales representative to begin the review process.

# COMMAND PRO

14, 20 AND 25 HP OHV VERTICAL/HORIZONTAL SHAFT

## MODEL SPECIFICATIONS

ENGINE TYPE	4-cycle, air-cooled, gasoline, horizontal and vertical shaft, single-cylinder, overhead valve, cast iron cylinder liner, LPG fuel system.	
MODEL	CH14	CV14
SPEC	Special Order	PA-14106
FUEL SYSTEM	LPG, closed loop	LPG, closed loop
TYPE OF FUEL WITHDRAWAL	Vapor	Vapor
MUFFLER	Catalytic pillow, w/guard	Catalytic pillow, w/guard
BORE in. (mm)	3.43 (87)	3.43 (87)
STROKE in. (mm)	2.64 (67)	2.64 (67)
DISPLACEMENT cu. in. (cc)	24.3 (398)	24.3 (398)
POWER (@3600 RPM)* hp (kW)	10.27 (7.66)	10.27 (7.66)
MAX TORQUE (@ RPM) lbs. ft	17.29 (@ 1800)	17.29 (@ 1800)
COMPRESSION RATIO	8.5:1	8.5:1
DRY WEIGHT lbs. (kg)	89.3 (40.5)	89.0 (40.4)
OIL CAPACITY U.S. pints (litre)	4 (1.9)	4 (1.9)
DIMENSIONS L x W x H in. (mm)	**13.74" x 22.52" x 18.58" **349 x 572 x 472	***18.46" x 18.43" x 13.66" ***469 x 468 x 347

\*Horsepower ratings (shown as NET) are in accordance with Society of Automotive Engineers - Small Engine Test Code J1349.

\*\* Length is mounting face to recoil start. (Subtract 2.35" if no recoil start.) Width is throttle lever to LPG regulator. Height is mounting feet to muffler.

\*\*\* Length is muffler to crankcase. Width is muffler to LPG regulator. Height is mounting face to recoil start. (Subtract 1.36" if no recoil start.)

ENGINE TYPE	4-cycle, air-cooled, gasoline, horizontal shaft, twin cylinder, overhead valve, cast iron cylinder liners (CH20), plated cylinders (CH25), various fuel systems.				
MODEL	CH20	CH25	CH25	CH25	CH25
SPEC	PA-64570	PA-68640	Special Order	Special Order	Special Order
FUEL SYSTEM	LPG, open loop	LPG, open loop	Dual, closed loop	Dual, open loop	LPG/NG, open loop
TYPE OF FUEL WITHDRAWAL	Liquid	Liquid	Liquid	Liquid	Liquid
MUFFLER	Canister	Canister	Canister	Canister	Canister
BORE in. (mm)	3.03 (77)	3.27 (83)	3.27 (83)	3.27 (83)	3.27 (83)
STROKE in. (mm)	2.64 (67)	2.64 (67)	2.64 (67)	2.64 (67)	2.64 (67)
DISPLACEMENT cu. in. (cc)	38 (624)	44 (725)	44 (725)	44 (725)	44 (725)
POWER (@3600 RPM)* hp (kW)	LPG 17.1 (12.8)	20.0 (14.9)	18.2 (13.6)	18.8 (14.0)	19.9 (14.8)
	Gasoline -	-	21.5 (16.1)	21.5 (16.1)	-
	NG -	-	-	-	17.4 (12.9)
MAX TORQUE (@ RPM) lbs. ft	LPG 28.6 (@ 2400)	34.3 (@ 2400)	31.1 (@ 1800)	31.4 (@ 2400)	32.0 (@ 3000)
	Gasoline -	-	33.7 (@ 2400)	33.7 (@ 2400)	-
	NG -	-	-	-	28.7 (@ 3000)
COMPRESSION RATIO	8.5:1	9:1	9:1	9:1	9:1
DRY WEIGHT lbs. (kg)	92 (41.7)	96 (43.5)	97.5 (44.2)	97.5 (44.2)	96 (43.5)
OIL CAPACITY U.S. pints (litre)	4 (1.9)	4.2 (2)	4.2 (2)	4.2 (2)	4.2 (2)
DIMENSIONS L x W x H in. (mm)	See #1 below See #1 below	See #2 below See #2 below	See #3 below See #3 below	See #4 below See #4 below	See #5 below See #5 below

\*Horsepower ratings (shown as NET) are in accordance with Society of Automotive Engineers - Small Engine Test Code J1349.

#1 - 14.19(360) x 18.5(470) x 19(483) Length is grass screen to vaporizer (or 19/482 to muffler). Width is to vaporizer hose.

#2 - 15(381) x 21(533) x 19.75(502) Length is grass screen to vaporizer (or 19.5/495 to muffler). Width is to lock-off solenoid. Height is to air cleaner.

#3 - 15(381) x 21(533) x 20.75(527) Length is grass screen to vaporizer (or 19.5/495 to muffler). Width is to lock-off solenoid. Height is to air cleaner.

#4 - Same as #3.

#5 - 14(356) x 19.25(489) x 20.5(521) Length is grass screen to mounting surface (or 19.5/495 to muffler). Width is to regulator. Height is to air cleaner.



Certification #US97/0977

FOR MORE INFORMATION, CONTACT YOUR KOHLER SOURCE OF SUPPLY,  
OR CALL 1-800-544-2444

KOHLER CO., KOHLER, WISCONSIN 53044 TOLL FREE US AND CANADA 1-800-544-2444 TEL 920-457-4441 FAX 920-459-1570  
www.kohlerengines.com

©1999 by Kohler Co. All rights reserved.

**KOHLER**  
**engines**  
**BORN TO RUN™**

Printed in USA E-2056 599